



Max Charge MC-612 Installation And Operation Manual



TABLE OF CONTENTS

I. Introduction	1	VII. Programming Modes	9-11
II. Safety Considerations	1	VIII. System Troubleshooting.....	12-13
III. Installation Guide.....	2-5	IX. Suggested Wiring Configurations.....	14-15
IV. Optional Wiring Connections	5-6	Express Installation Instructions	16
V. Regulator Operation	7	Warranty.....	16
VI. Regulator Display Modes	8		

I. Introduction

The microprocessor-controlled Max Charge MC-612 is the most advanced regulator available. The MC-612 lets you choose from a variety of selectable preset programs to best suit your charging needs. Its Universal Factory Program allows you to connect the MC-612 to your alternator right out of the box. Six additional preset programs support most popular battery types, including standard and deep-cycle flooded batteries, AGM, gel, and Optima (spiral wound) technologies, as well as special settings for systems supplying halogen lighting. An easy-to-use magnetic reed switch delivers quick, precise regulator adjustment. Should your charging system require individualized adjustment, the MC-612 provides additional advanced user-defined programming options.

When used with optional alternator and battery temperature sensors, the MC-612 automatically monitors ambient alternator and battery temperatures and compensates by adjusting field output to match conditions. Alarm outputs connect to audible or visual alarms to provide warnings of dangerous system conditions.

II. Safety Considerations

Before installing your MC-612 marine regulator, please take a moment to consider these guidelines for safe regulator installation. Failure to work safely could result in injury or damage to your electrical system.

1. Always disconnect your battery banks and ensure that switches are "OFF" prior to installing your regulator.
2. Remove loose-fitting clothing or jewelry, which could become entangled in your motor or other machinery.
3. Wear ANSI-approved safety glasses.
4. DO NOT attempt to modify the regulator. Alterations could result in damage to your charging system, and will void your warranty.
5. Do not attempt installation if tired or fatigued.
6. Ensure the engine has cooled before initiating installation.
7. Do not attempt installation while using alcohol or medication that could impair your judgment or reaction time.
8. Always use the right tool for the job. Improper tool use may damage regulator or your boat, and could result in personal injury.
9. Take time to read the manual. Equipment damage and possible injuries may result from an incomplete understanding of the installation and operation of the MC-612 regulator. If you are unfamiliar with marine electrical systems, consult with a licensed marine electrician.

Caution

The following instructions are intended for use by experienced marine electrical installers. If you are not experienced at installing electrical system components, we recommend the use of a qualified marine electrical technician.

III. Installation Guide

The following information is intended to provide the installer with the basic information required to complete installation. This section of the installation manual will deal with mounting, wiring connections and basic programming for battery type. Additional information regarding advanced programming adjustments and troubleshooting are addressed later in the manual.

A. Unpack The Box

Your Max Charge MC-612-H regulator kit is packaged with the following items:

1. Max Charge regulator
2. 54" wiring harness w/ fuse (10A) on RED power wire
3. Fused (1A) battery sense wire pigtail
4. Magnetic programming tool
5. Installation and operation manual

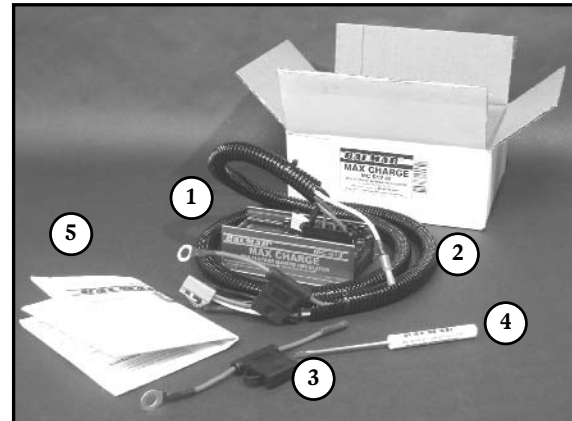

If any of the listed items is not included with your regulator kit, call our customer service department at 360-435-6100. Please note -- if your regulator box is marked Max Charge MC-612, without the "H" designation, your kit will not include the wiring harness or fused battery sense pigtail.

B. Locate And Mount The Regulator

Choosing a mounting location for your voltage regulator should be determined based on the following factors; distance from alternator, distance from inverters, transmitters and other sources of RF noise, convenient access and readability of the display. The regulator wiring harness is 54 inches long, providing a three to four foot radius for mounting.

Ample airflow is essential for the regulator's proper operation. Ensure that the regulator is free from obstructions that restrict air movement around or below the regulator's heat aluminum heat sink.

Should it be necessary to install the regulator further than the harness's 54" length from the alternator, ensure that any wire extensions are properly connected, as resistance in the harness wiring can reduce charging efficiency or hamper the regulator's ability to accurately respond to battery conditions. If harness length must reach beyond approximately eight feet, replace the existing harness wires with larger gauge wire.

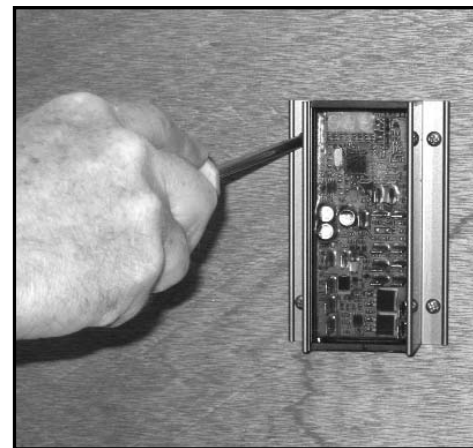

C. Basic Wiring Installation (Topics D to K)

The regulator's wiring harness includes six wires required for standard installation. Four of those wires are connected to the regulator via a Ford-style plug connector that's pre-installed on the regulator. These wires include the Ground (BLACK), Power (RED), Ignition (BROWN) and Field (BLUE). Plug is shown at right. In addition, the harness includes a separate Ground (BLACK) and Stator (WHITE) wire. The proper terminal connection points for these, and additional wiring connections, are illustrated on the pin location legend shown and discussed on the following pages.

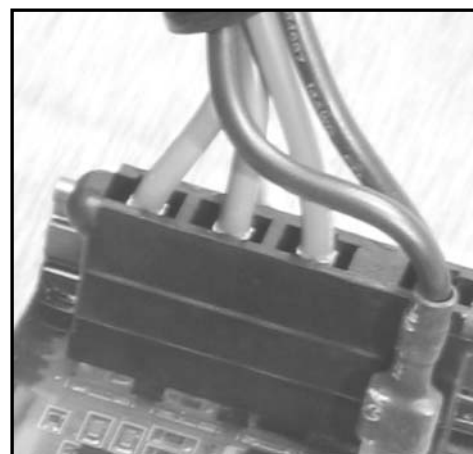

MC-612 Regulator Layout

1. **Magnetic Reed Switch** - Activated by placing magnetic tip of programming tool against one or the other end. See illustration in "Programming" section later in this manual.
2. **Positive Sense Wire** - Connects to independent fused wire included with regulator. Wire must see battery voltage directly for proper operation. See details in text.
3. **Ground (Independent)** - Connects to individual ground (BLACK) wire in wiring harness. Pre-connected at factory in regulator packages with harness included.
4. **Ground (BLACK)** - Included in Ford-style plug.
5. **Power (RED)** - Supplies power to operate the regulator and delivers field current to excite alternator. Included in Ford-style plug.
6. **Ignition (BROWN)** - Serves as "ON/OFF switch" for regulator. Must see zero volts when engine ignition is off and battery voltage when the ignition is on. May also be activated by an oil pressure switch. Included in Ford-style plug.
7. **Field (BLUE)** - Supplies amperage to the alternators brushes to excite the regulator. The regulator will increase or decrease voltage/amperage on the field to maximize charging without exceeding safe operating voltages. Included in Ford-style plug.

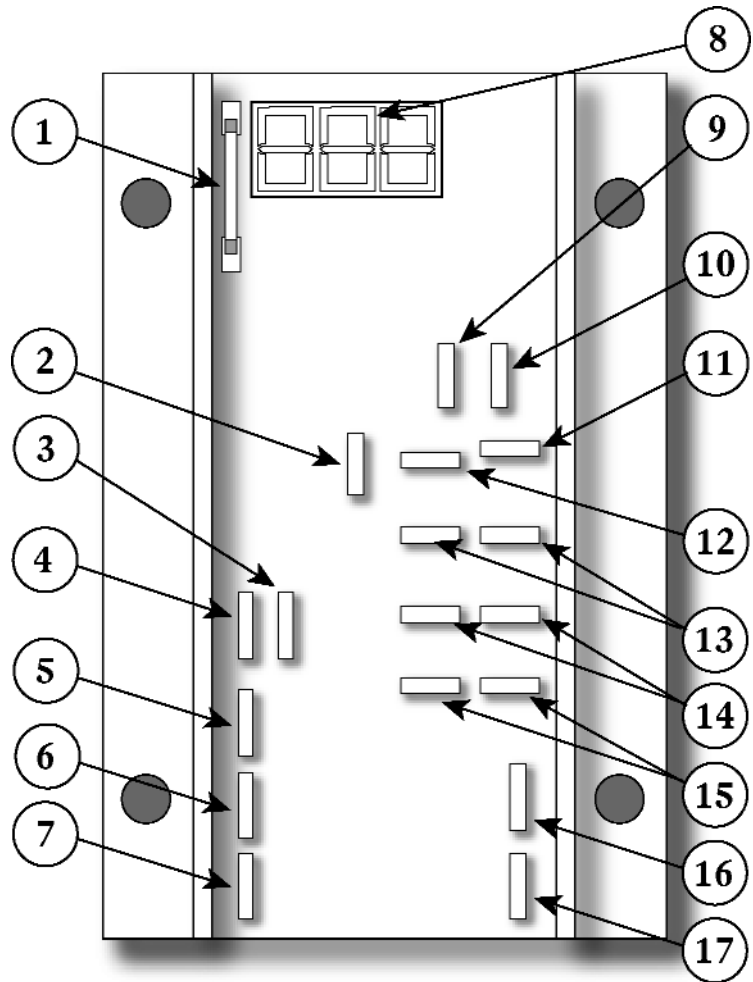

8. **Digital Numeric Display** - Three-digit numeric display provides an easy-to-use interface for operational and programming modes.
9. **Stator Input** - Connects (WHITE) stator input from alternator to tach output to electric tachometer. When the tachometer is connected to the alternator via the regulator's Stator Input and Tach Output (#10), the regulator will automatically enable a minimum field current value, which will minimize tach bounce when the batteries reach full charge.
10. **Tach Out** - Connects alternator stator output to an electric tachometer via the regulator. See information above.
11. **Data RX** - Not currently used. Provides input connection for planned remote display.
12. **Data TX** - Not currently used. Provides output connection for planned remote display.
13. **Alternator Temperature Sensor** - Positive and negative terminal pins for use with optional Alternator Temperature Sensor (MC-TS-A). When connected, the temperature sensing function allows the regulator to respond to over-temperature conditions at the alternator by reducing field output to the alternator. Reducing field output reduces load on alternator and belts, allowing the alternator to cool down. In addition, the regulator activates the Dash Lamp terminal (#17) so a warning lamp or audible alarm can be used to indicate an over-temperature condition.
14. **Battery #2 Temperature Sensor** - Indicates over-temperature condition at secondary battery bank, when used with optional Battery Temperature Sensor (MC-TS-B). Regulator discontinues field current to the alternator when high battery temperature is sensed. Activates Dash Lamp (#17) when condition is indicated.
15. **Battery #1 Temperature Sensor** - Automatically compensates for changes in ambient battery temperature when used with optional Battery Temperature Sensor (MC-TS-B). Regulator discontinues field current to the alternator when high battery temperature is sensed. Activates Dash Lamp (#17) when condition is indicated.
16. **Aux. 1 Output** - Terminal goes to ground when the following conditions occur: alternator output at full capacity, Small Engine Mode activated, Equalization Mode activated. Can be connected to ground side of lamp or audible alert device.
17. **Dash Lamp** - Terminal goes to ground when the following conditions occur: low system voltage, high system voltage, high alternator temperature, high battery temperature. Can be connected to ground side of lamp or audible alert device.

D. Install Ground Wires

Two BLACK Ground Wires are included in the regulator's wiring harness. One of the two wires is connected via the Ford-style plug (#4 in diagram at right). The other is connected at the independent terminal shown (#3 in diagram at right). Both wires are connected to the regulator at the factory. The other end of each wire is fitted with a ring terminal. Both wires should be connected at the alternator's ground terminal. See your alternator's instruction manual for the ground terminal connection point.

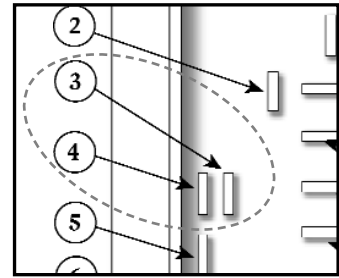

E. Install Power Wire

The RED Power Wire (#5 in diagram at right) is included in the four-wire Ford-style plug and is factory installed on the regulator. The other end of the Power Wire is fitted with a ring terminal connector. In most applications, this wire can be connected directly to the alternator's positive output post. In an isolator is used, it will be necessary to connect the ring terminal to the battery side of the isolator. The Power Wire should be connected to the same location as the Positive Battery Sense Wire (see below). The Power Wire features a 10-amp ATC type fuse and fuseholder. This wire must be fused.

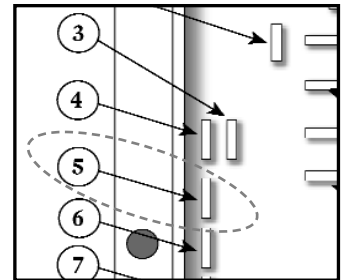

F. Install Positive Battery Sense Wire

Included with the MC-612's wiring harness kit is a fused wiring pigtail which features a ring terminal at one end and a butt connector at the other. In the center is a 1-Amp ATC-type fuse and fuse holder. This wire must be connected at the Positive Battery Sense terminal located at the center of the regulator's circuit board. See terminal #2 in diagram at right. A female quick connect plug has been pre-attached on terminal #2 for connection of the positive battery sense wire at the regulator. To complete installation of the sense circuit:

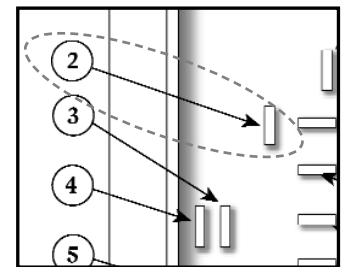

Identify the favored location for battery sensing. In most instances, the positive output of the alternator, the common side of a battery switch, or the positive post of the battery being charged will work best. If the batteries are connected to an isolator, the positive sense wire must be connected to the battery side of the isolator, preferably at the larger of the battery banks. If the length of the wire run between the regulator and the sensing location is 8' or less, a 16-gauge wire is satisfactory. If the wire run exceeds 8', increase the wire size to 14 gauge.



G. Install Ignition Wire

The BROWN Ignition Wire (#6 in diagram at right) provides the ON/OFF voltage for the regulator. This wire is included in the Ford-style plug at the regulator. The other end of the wire is fitted with a butt connector. Typically, the ignition wire is connected to the ON side of the ignition switch. This may be at the actual switch, or to the wire in the existing engine wiring loom that delivers switched voltage from the ignition switch. In some cases, an oil pressure switch may be used to activate the regulator. In either case, the regulator's ignition wire must see zero volts when the engine ignition is switched off.

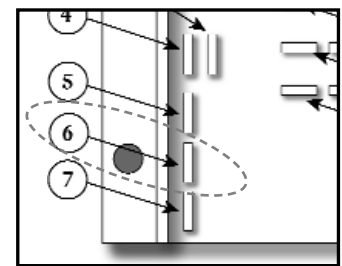

H. Install Field Wire

The BLUE Field Wire (#7 in diagram at right) provides the regulated voltage to the alternator required to excite the rotor and stator and control alternator output. The Field wire is included in the Ford-style plug and is pre-connected at the regulator. At the other end of the wire, you'll find either a plug or a ring terminal, depending on the alternator's field terminal connection. Attach the field wire to the alternator's field terminal. See your alternator manual for any specific requirements your alternator may have.

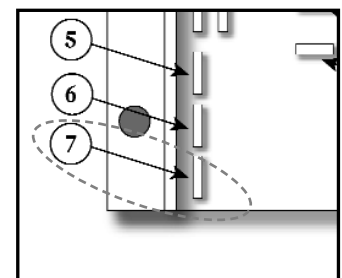

I. Install Stator-In And Tach-Out Wires

When an electric tachometer is used, the alternator's stator output will provide the electrical pulse needed to drive the tachometer. The MC-612 has been designed to provide regulated tach output when the WHITE stator wire is connected to the regulator's Stator In (#9 in diagram) terminal and the outfeed wire to the electric tachometer is connected to the Tach Out terminal (#10 in diagram). When the tachometer is connected via the MC-612, the regulator will ensure that the tachometer will not drop out when the batteries are fully charged.

When connecting the tachometer to the alternator stator output, it will be necessary to determine the number of poles in the alternator in order to properly adjust your tachometer. Most Balmar alternators feature 12-pole rotors and stators, though, in some cases, the pole count may be 14. See alternator manual for specifics. See your tachometer manual for adjustment instructions.

J. Data TX and RX terminals (not used)

Intended for factory diagnostic testing only. Do not connect any wires to the Data TX or Data RX terminals (#11 and #12 in diagram).

K. Initial Start-Up

With all of the wiring connections installed between the alternator and voltage regulator, as described in steps C through J, the regulator is ready for initial start up. To test the regulator for proper operation:

- A. Reconnect the battery cables to the batteries and turn battery switches to the on position.
- B. Turn the ignition switch to the ON position. If the regulator's BROWN ignition wire was connected to an oil pressure switch, it may be necessary to start the engine. If that is necessary, be sure to inspect for any loose or disconnected wires, inspect and adjust alternator belt tension if necessary.
- C. With the ignition on and/or with the engine running, the regulator's LED should scroll through the basic regulator display. If the engine is running, the charging voltage will begin to climb to 14.1 volts.

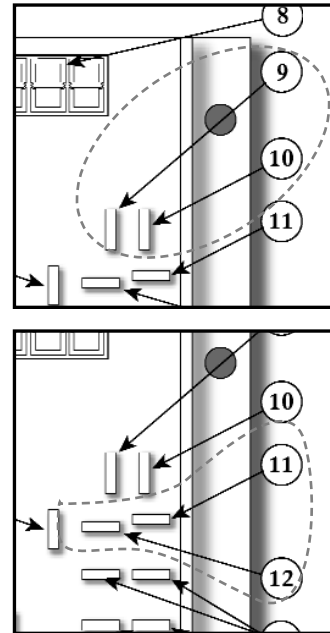

IV. Optional Wiring Connections

Once the regulator is up and functioning, you can shut it down and continue the installation of the remaining wiring options, or continue on to the Basic Programming instructions in Section V.

A. Install Alternator Temperature Sensor

The optional Alternator Temperature Sensor (MC-TS-A) allows your Max Charge voltage regulator to monitor your alternator for temperatures in excess of safe operating levels. The MC-TS-A sensor assembly includes a 54" cable, a sensing attachment lug and positive and negative regulator plug-in connectors. To install the MC-TS-A:

1. Connect the sensor lug to one of the four bolts that hold the alternator's front and rear cases together. See photo at right.
2. Extend sensor cable to the regulator. The cable can be included within the regulator's wiring harness, or can be run alongside the harness and attached with cable ties.
3. Connect the positive and negative female connectors to the Alternator Temp. Sense terminals on the regulator (#13). It is essential that the terminals match the polarity of the regulator connection pins (red wire to positive terminal and black wire to negative terminal). See the legend on the side of the regulator to determine terminal polarity.

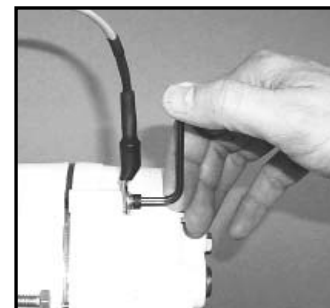
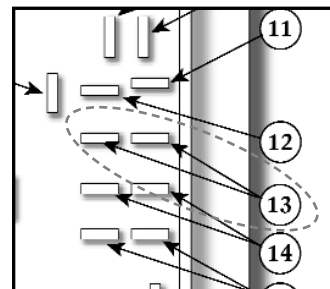

Small Engine Mode

The MC-612 can be switched to provide a half-power setting by installing a toggle switch between the positive and negative terminals of the alternator temp sensor circuit. When activated by closing the switch, the regulator reduces the alternator output by a maximum 50%. This mode is ideal for smaller engines that are not capable of providing suitable horsepower to drive both the alternator and propeller at full output. When in Small Engine Mode, the regulator will send a signal to the Aux. 1 Output.

B. Install Battery Temperature Sensors

Optional Battery Sensors (MC-TS-B) allow your Max Charge voltage regulator to monitor battery temperatures. The Max Charge is equipped with terminals to monitor two battery banks. The MC-TS-B sensor assembly includes a 240" cable, a sensing attachment lug and positive and negative regulator plug-in connectors. When connected to Battery 2 Temp (#14) on the regulator, the temperature sensor will monitor for over-temperature conditions only. Typically, Battery 2 Temp is used to monitor the starting battery. Should an over-temp condition occur, the regulator will respond by ceasing charging output to the batteries.

Battery 1 Temp will also monitor for, and respond to battery over-temp conditions by ceasing charging output. In addition, the Battery 1 Temp circuit will also increase or decrease charging voltage if it senses that ambient battery temperature is warmer or colder than 75°F. The Battery 1 Temp circuit (#15) is recommended for use with the house battery bank. To install the MC-TS-A:

1. Connect the sensor lug to the negative post of your house battery. See photo above. If there are multiple batteries in the bank, place the sensor lug on the negative terminal CLOSEST to the center of the battery bank.
2. Extend sensor cable to the regulator.
3. Connect the positive and negative female connectors to the appropriate Battery Temp. Sense terminals on the regulator (#14 or #15). It is essential that the terminals match the polarity of the regulator connection pins (red wire to positive terminal and black wire to negative terminal). See the legend on the side of the regulator to determine terminal polarity.

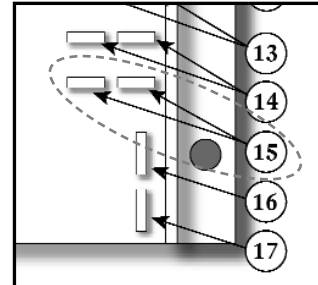
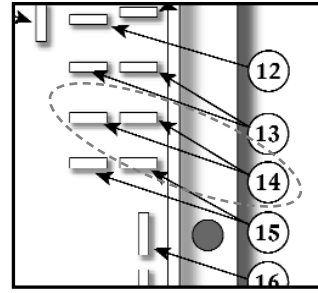

C. Install Aux. 1 Lamp

The Max Charge Aux. 1 (#16) terminal provides the ability to use a visual indicator when the regulator is operating under the following conditions: Full field (the alternator is working at full power), Small Engine Mode (the regulator is being controlled at 50% field output), or Equalization Mode (the batteries are being intentionally over-charged to remove sulfation). When a described condition is detected, the regulator sends the Aux. 1 terminal from neutral to ground. To utilize the Aux. 1 Lamp function:

1. Connect a small LED or incandescent lamp (maximum current flow is 500 mA) to a positive voltage source.
2. Connect the negative terminal on the lamp to the Aux. 1 terminal on the regulator.

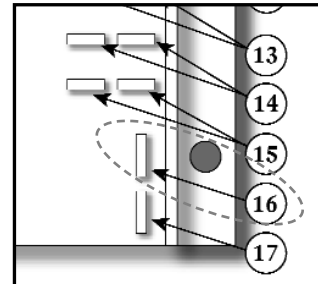

D. Install Dash Lamp

The Max Charge Dash Lamp (#17) terminal provides the ability to activate a visual or audible indicator when the regulator monitors the following conditions: Low system voltage, high system voltage, high alternator temperature and high battery temperature (temperature conditions are only indicated when appropriate temperature sensors are connected). When a described condition is detected, the regulator sends the Dash Lamp terminal from neutral to ground. To utilize the Dash Lamp function:

1. Connect a small LED or incandescent lamp, or an audible (piezo) alert (maximum current flow is 500 mA) to a positive voltage source.
2. Connect the negative terminal on the lamp or audible alert to the Dash Lamp terminal on the regulator.
3. When connected, the lamp should flash at regulator start-up to indicate active status.

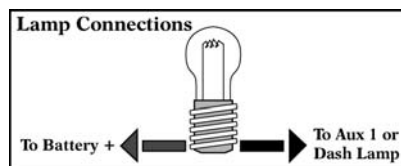
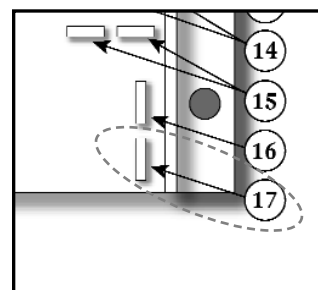

Alarm Output Functions

Alarm Output (Dash Lamp)

- (-) 0.5 amp - when in alarm mode
- Low battery voltage (030)
- High battery voltage (040)
- High temperature at battery #1
- High temperature at battery #2
- High temperature at alternator

Aux. #1 (Advisory) Output

- (-) 0.5 amp - when in alarm mode
- Alt. output at full capacity
- Small engine option activated
- Equalization mode activated

V. Regulator Operation

The MC-612 regulator's microprocessor controlled charging system uses a sophisticated, multi-stage profile to deliver maximum charging output, while protecting the batteries from overcharging damage. When the regulator is first turned on, the processor performs a quick one-second self diagnostic assessment. Following that diagnostic, the MC-612 initiates a charge program as follows:

1. Start Delay - Factory set at one second. Can be user-adjusted to a maximum of 200 seconds in the regulator's advanced programming mode. See Advanced Programming section for adjustment instructions.
2. Soft Ramp - Slowly increases voltage to bulk preset levels based on battery program selected.
3. Bulk Charge - The most aggressive of the charging stages. Voltage is held at a pre-set level, specified by battery program selected, for a set time period. Factory-set bulk time is 30 minutes.
4. Calculated Bulk Charge - Holds voltage at bulk level for six minutes, then calculates battery condition by comparing existing voltage, time at voltage, and field percentage to target values. If values are met, the regulator advances to the next stage. If values are not met, the regulator extends the bulk charge time by an additional six minutes and compares real-time to target values. This will re-occur until all values are met.
5. Ramp to Absorption.
6. Absorption Charge - Regulator continues to control the alternator's output voltage for an additional 30 minutes, typically at two-tenths of a volt less than bulk voltage (based on battery program presets).
7. Calculated Absorption Charge - Holds voltage at absorption level for six minutes, then calculates battery condition by comparing existing voltage, time at voltage, and field percentage to target values. If values are met, the regulator advances to the next stage. If values are not met, the regulator extends the absorption charge time by an additional six minutes and compares real-time to target values. This will re-occur until all values are met.
8. Ramp to Float.
6. Float Charge - Regulator continues to control the alternator's output voltage for an additional 30 minutes, typically at a volt less than bulk voltage (based on battery program presets). Regulator will hold voltage to float level for two hours (time duration is user-adjustable). After that initial fixed time period, the regulator can respond to increased charging demand by reverting to absorption voltage. After six hours of continuous operation, the regulator will automatically revert to absorption voltage through calculated absorption and back to float charging stage.

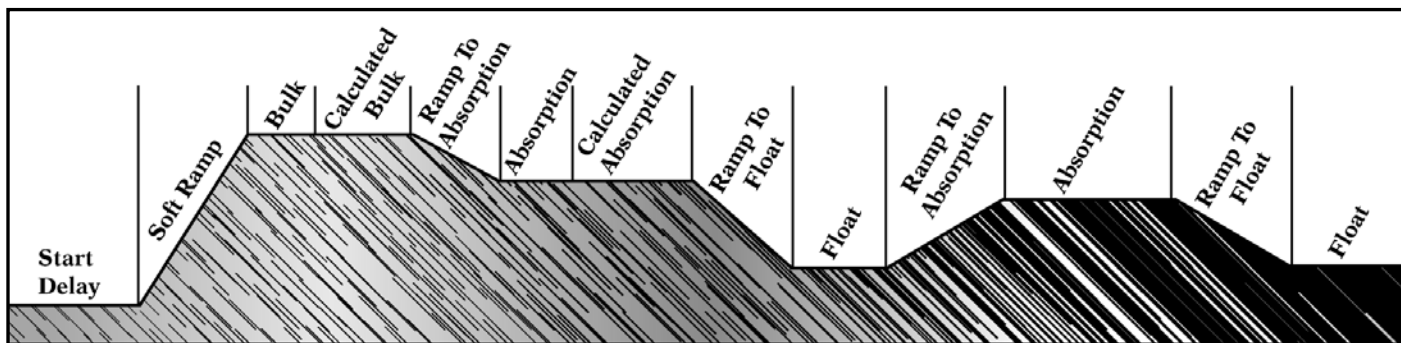

VI. Regulator Display Modes

A. Basic Display

The regulator's three digit alphanumeric LED display provides a scrolling view of charging status. Under normal operation, the display will indicate the following:

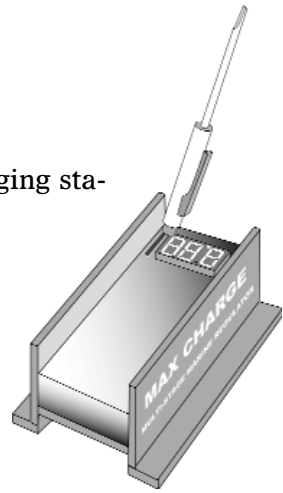

- **BAL** -- Indicates Balmar.
- **612** -- Indicates Max Charge MC-624-LN.
- **P01** -- Indicates battery program is set for Universal Factory Mode.
- **UFP** -- Verifies program set for AGM batteries.
- **50** -- (S) Indicates stage of charge. See chart and descriptions on previous page.
- **BU** -- Indicates "real time" battery system voltage. Followed by actual voltage reading.
- **CU** -- Indicates Calculated voltage (target voltage based on preset program levels). Followed by actual voltage reading.

B. Long Display

In addition to the regulator's short display, a longer, more in-depth display is available when the magnetic reed switch located next to the LED display is activated with a short touch of the magnetic programming screwdriver as shown at upper right. When activating the reed switch, place the magnetic tip of the screwdriver against the epoxy potting at one or the other end of the reed switch located on the circuit board in the upper left corner of the regulator.

In the long display, the LED will indicate the codes described on the previous page. In addition to the information provided in the short display, the display will indicate the following:

- **R1.8** -- Indicates software revision number. As of publication, the software version is Revision #1.8. The revision number may vary based on actual installation date.
- **B1** -- Indicates ambient temperature at battery bank. Actual temperature is shown in Celsius, following the B1 code on the display.
- **SLP** -- Voltage Compensation Slope. Indicates, in milliamps, the resistance value the regulator uses to control compensated charging voltage based on battery temperature.
- **AL1** -- Indicates ambient temperature at #1 alternator. Temperature reading is shown in Celsius, following the AL1 code on the display.
- **AL2** -- Indicates ambient temperature at #2 alternator. Temperature reading is shown in Celsius, following the AL2 code on the display.
- **AP** -- Indicates maximum field percentage as controlled by the Amp Manager feature in the Advanced Programming mode. 100 indicates Amp Manager is OFF. 50 indicates Amp Manager at 50%.
- **FE** -- Indicates percentage of regulator field output. 100 indicates regulator is driving alternator at full output. 50 indicates that the regulator is driving the alternator at approximately 50% output.
- **HR** -- Indicates total regulator hours. Will be followed by display in tens of hours and an additional display indicating 10ths of hours.
- **FBA** -- Indicates field threshold for bulk and absorption modes. Field threshold signifies the minimum field percentage required by the regulator to maintain the current state of charge. When field voltage drops below the field threshold in calculated bulk or absorption stages, the regulator advances to the next charging stage. Factory set threshold for calculated bulk and calculated absorption is 77%.
- **FFL** -- Indicates field threshold for the calculated float stage. If field voltage surpasses the maximum threshold value for calculated float percentage, the regulator will increase target voltage to absorption level. Factory set threshold for maximum calculated float is 77%.
- **E--** -- (Followed by a numeric designation) indicates a specific advisory code pertaining to the regulator's operation. See chart at right for details.

Event/Advisory Codes	
E01	Factory use only.
E02	Factory use only.
E10	Battery #1 temp. sensor shorted.
E11	Battery #1 temp. sensor open or not found.
E12	Battery #2 temp. sensor shorted.
E13	Battery #2 temp. sensor open or not found.
E14	Alternator temp. sensor shorted.
E15	Alternator temp. sensor open or not found.
E16	Aux. Pickup Shorted
E17	Aux. Pickup open or not found.
E20	Battery #1 temp. too hot
E21	Battery #2 temp. too hot
E22	Alternator temp. too hot
E23	Aux. voltage too high.
E24	Regulator exceeding allowable temperature
E30	Charging voltage below acceptable limits
E31	Open field at alternator. Check system ground.
E32	Open stator at alternator. Possible winding failure.
E33	Aux. voltage too low.
E34	Battery voltage below acceptable limits.
E40	Battery voltage above acceptable limits.
E41	Field voltage above acceptable limits.
E42	Stator voltage above acceptable limits.
E43	Aux. voltage above acceptable limits.
E47	Advisory codes (E51 to E53) are in effect.
E51	Engine is in operation.
E52	Amp Manager mode is engaged.
E53	RPM emulator function is engaged.

VII. Programming Modes

A. Basic Programming

The Max Charge features six selectable programs for commonly used battery types: standard flooded, deep cycle flooded, gel, AGM, Optima spiral wound, halogen (voltage sensitive), as well as a default program that's safe for most battery types. To select the program that best suits your battery type:

1. Turn the ignition switch to the ON position. If an oil pressure switch is used, it may be necessary to start the engine to engage the regulator.
2. Once the regulator is activated and the numeric display is illuminated, activate the regulator's reed switch with the supplied magnetic screwdriver. Continue to hold the magnetic tip of the screwdriver against the reed switch.
3. The display will indicate entry into the Basic Programming mode with the code "PRO". As you continue to hold the magnet to the reed switch, the regulator will scroll through the battery program choices shown in the chart at right.
4. Select the preset programming that best suits your battery type. When the program number matching your battery type is indicated on the display, release the switch by lifting the screwdriver off of the epoxy potting.
5. Should you miss the desired program setting, simply re-activate and hold the switch as described on the previous page. Once the programming display begins to scroll upward, release the switch and wait for the "PRO" code. When the "PRO" code is illuminated, re-activate and hold the magnet to the switch. The display will scroll in the opposite direction. Release the magnet from the switch as soon as the display indicates your intended battery program.
6. After the switch is released, the regulator display will indicate "PRO". If further adjustments are required, re-activate the switch as previously described. If no additional adjustments are made, the display will indicate "SAU", at which point, the regulator will save any changes to the programming and the regulator will restart.
7. Programming success can be monitored by the watching the regulator's display after restart. The short display should indicate both program number and program code, as described on the chart shown above.

Preset Battery Programming

Program Number	Program Code	Program Description
P01	UFP	Universal Factory Program - Safe for most marine and vehicle battery types. Default setting.
P02	FDC	Deep Cycle Flooded - Specifically suited for thick plate, storage type flooded lead acid batteries.
P03	bEL	Gel - Specifically suited for sealed batteries with electrolyte held in a gel medium.
P04	AGL	Absorbed Glass Mat - Suited for sealed batteries with electrolyte suspended in saturated glass mat.
P05	OPS	Optima - Suited for spiral wound Optima batteries.
P06	FSB	Standard Flooded - Suited for thin plate, cranking type flooded lead acid batteries.
P07	HAL	Halogen/Voltage Sensitive - Specifically suited to applications supporting voltage sensitive lighting

Mastering The Magnetic Reed Switch

'ACTIVATE-RELEASE' Refers to the activation and immediate deactivation of the switch by lowering the magnetic programming tool onto the potting covering the reed switch, and immediately deactivating the switch by removing the magnet from the epoxy. An LED dot between the second and third digits on the display will indicate switch activation.

'ACTIVATE - HOLD - RELEASE' Typically used during programming, this action requires holding the magnet to the switch until desired values are shown on the display. Once the desired setting is reached, the magnet is removed to deactivate the switch.

Note: Program function will alternately cycle up or down each time the programming mode is activated. If you miss your desired program value, release the switch, wait for the program mode display (eg., PRO), and re-activate the switch. The direction of scroll will reverse. Any advanced programming values will be retained within the regulator's memory until the preset battery programming is reset.

Primary Program Settings	PRG-1	PRG-2	PRG-3	PRG-4	PRG-5	PRG-6	PRG-7
Mode	Universal Factory Program	Deep Cycle Flooded Lead Acid	Gel Cell	Absorbed Glass Mat (AGM)	Optima Spiral Wound	Standard Flooded Lead Acid	Halogen Voltage Sensitive
Start Delay (Seconds)	45	45	45	45	45	45	45
Ramp Up (Seconds)	60	60	60	60	60	60	60
Bulk Voltage (Max)	14.10	14.60	14.10	14.38	14.60	14.40	14.00
Bulk Time (Minimum)	36 min.	36 min.	36 min.	36 min.	36 min.	36 min.	36 min.
Absorption Voltage	13.90	14.40	13.90	14.18	14.40	14.20	13.80
Absorption Time (Minimum)	36 min.	36 min.	36 min.	36 min.	36 min.	36 min.	36 min.
Float Voltage	13.42	13.35	13.70	13.38	13.40	13.40	13.50
Float Time (Maximum)	6 hr.	6 hr.	6 hr.	6 hr.	6 hr.	6 hr.	6 hr.
High Voltage Alarm	15.20	15.60	15.10	15.38	15.60	15.40	15.00
Low Voltage Alarm	12.80	12.80	12.80	12.80	12.80	12.80	12.80
Max Battery Temperature	125F/52C	125F/52C	125F/52C	125F/52C	125F/52C	125F/52C	125F/52C
Max Alternator Temperature	225F/107C	225F/107C	225F/107C	225F/107C	225F/107C	225F/107C	225F/107C
Equalization (User Prog.)	Yes	Yes	No	Yes	No	Yes	No

B. Advanced Programming Mode

Among its intelligent features, the MC-612 provides a wide range of advanced programming modes to provide increased performance or greater safeguard for batteries and alternator. Programming modes include time and voltage adjustment in bulk, absorption and float modes, start delay time adjustment, voltage compensation limits, Amp Manager field percentage control, and equalization controls. Adjustments for bulk, absorption and float field voltage thresholds are also available. To access advanced programming modes:

1. Turn the ignition switch to the ON position. If an oil pressure switch is used, it may be necessary to start the engine to engage the regulator.
2. Once the regulator is activated and the numeric display is illuminated, activate the regulator's reed switch with the supplied magnetic screwdriver. Continue to hold the magnetic tip of the screwdriver against the reed switch. The display will indicate entry into the Basic Programming mode with the code "PRO". As soon as the "PRO" display is indicated, release the switch by removing the magnet from the magnetic reed switch.
3. The regulator's display will indicate entry to the advanced programming mode with the "PRA" code.
4. Once in "PRA" mode, the regulator's display will scroll through the advanced programming options indicated in the chart shown at right.

During the period that the regulator scrolls through the various advanced programming options, you will have three opportunities to make adjustments. To activate a specific programming mode:

1. Identify the programming code that you want to access.
2. When the desired code is indicated, activate and hold the magnetic reed switch with the magnetic programming tool. The display will indicate the set value for that mode.
3. As you continue to hold the magnet to the reed switch, the various programming values will be shown on the display. Individual modes are described below:

- **DLC** -- Start Delay. Controls the amount of time from regulator activation to start of charging. Factory preset at one second. Can be adjusted to a maximum of 200 seconds. To reverse direction of scroll, release magnet and wait for LED to display **DLC** code. Re-activate switch with magnet and release when desired value is indicated.
- **CL** -- Compensation Limit. Controls the maximum limit of allowable system voltage. Starts at value set by battery program currently in use. Adjustment spans from 14.1 to 15.9 volts. To reverse direction of scroll, release magnet and wait for LED to display **CL** code. Re-activate switch with magnet and release when desired value is indicated.
- **Bu** -- Bulk voltage adjustment. Controls the maximum limit of allowable bulk voltage. Starts at value set by battery program currently in use. Adjustment spans from 14.1 to 14.8 volts. To reverse direction of scroll, release magnet and wait for LED to display **Bu** code. Re-activate switch with magnet and release when desired value is indicated.
- **B1c** -- Bulk time adjustment. Controls the minimum time period for non-calculated bulk charging. Standard value set by battery program selected. Adjustment spans in tenths of hours from 12 minutes to six hours. To reverse direction of scroll, release magnet and wait for LED to display **B1c** code. Re-activate switch with magnet and release when desired value is indicated.

Advanced Program Modes

Program Code	Program Mode Description	Adjustment Range
DLC	Start delay time adjustment. Controls time period before regulator excites alternator field wire.	In seconds 1 to 200
CL	Compensation limit. Controls maximum allowable regulator voltage compensation limits.	In volts 14.1 to 15.9
Bu	Bulk voltage adjustment. Controls maximum voltage level during bulk charging stage.	In volts 14.1 to 14.8
B1c	Bulk time adjustment. Controls length of minimum bulk time period.	In 1/10-hr. 002 to 060
Au	Absorption voltage adjustment. Controls maximum voltage level during absorption charging stage.	In volts 13.5 to 14.8
A1c	Absorption time adjustment. Controls length of minimum absorption time period.	In 1/10-hr. 002 to 060
Fu	Float voltage adjustment. Controls maximum voltage level during float charging stage.	In volts 13.0 to 13.8
F1c	Float time adjustment. Controls length of maximum non-calculated float time period.	In 1/10-hr. 002 to 060
AP	Amp Manager. Governs maximum allowed field percentage, and subsequent alternator output.	2% Increments 0 to 100%
Eu	Equalization voltage adjustment. Controls maximum voltage level during equalization.	In volts 14.8 to 16.5
E1c	Equalization time adjustment. Controls length of equalization/conditioning period.	In 1/10-hr. 005 to 030
FBR	Controls minimum field percentage required to keep regulator operating at bulk or absorption stages.	2% Increments 16 to 96%
FFL	Controls maximum field percentage required to keep regulator operating at float stage.	2% Increments 16 to 96%
AL1	Controls alternator temperature setpoint prior to automatic reduction to 50% field (requires temp sensor).	Degrees Celcius 30C to 125C

- **AU** -- Bulk voltage adjustment. Controls the maximum limit of allowable bulk voltage. Starts at value set by battery program currently in use. Adjustment spans from 13.5 to 14.8 volts. To reverse direction of scroll, release magnet and wait for LED to display **AU** code. Re-activate switch with magnet and release when desired value is indicated.
- **ATC** -- Bulk time adjustment. Controls the minimum time period for non-calculated absorption charging. Standard value set by battery program selected. Adjustment spans in tenths of hours from 12 minutes to six hours. To reverse direction of scroll, release magnet and wait for LED to display **ATC** code. Re-activate switch with magnet and release when desired value is indicated.
- **FU** -- Bulk voltage adjustment. Controls the maximum limit of allowable float voltage. Starts at value set by battery program currently in use. Adjustment spans from 13.0 to 13.8 volts. To reverse direction of scroll, release magnet and wait for LED to display **FU** code. Re-activate switch with magnet and release when desired value is indicated.
- **FTC** -- Bulk time adjustment. Controls the minimum time period for non-calculated float charging. Standard value set by battery program selected. Adjustment spans in tenths of hours from 12 minutes to six hours. To reverse direction of scroll, release magnet and wait for LED to display **FTC** code. Re-activate switch with magnet and release when desired value is indicated.
- **AP** -- Amp Manager. Governs the maximum field potential percentage allowed. Can be used to de-tune alternator output. When "AP" is displayed on the LED, activate switch. "OFF" code will be displayed. Release switch. When "AP" is indicated, re-activate and hold switch with magnetic tool. Display will decrement through percentage values (98, 96, 94, and so on). Release when the desired percentage is indicated.
- **EU** -- Equalization voltage adjustment. Governs equalization/conditioning voltage. Starts at value set by battery program currently in use. Adjustment spans from 14.8 to 16.5 volts. To reverse direction of scroll, release magnet and wait for LED to display **EU** code. Re-activate switch with magnet and release when desired value is indicated.
- **ETC** -- Equalization time adjustment. Controls the time period for equalization/conditioning charging. Adjustment spans in tenths of hours from 30 minutes to three hours. To reverse direction of scroll, release magnet and wait for LED to display **ETC** code. Re-activate switch with magnet and release when desired value is indicated.
- **FBR** -- Controls the criteria the regulator uses to determine how hard the alternator has to be working to stay in calculated bulk charging mode. Factory set at 75% field output. Raising "FBR" shortens calculated bulk charge time. Lowering "FBR" increases calculated bulk charge time. Adjusted in 2% increments. Span of adjustment is 16% to 96%. To reverse direction of scroll, release magnet and wait for LED to display "FBR" code. Re-activate switch with magnet and release when desired value is indicated.
- **FFL** -- Controls the criteria the regulator uses to determine how hard the alternator has to be working to stay in calculated absorption charging mode. Factory set at 75% field output. Raising "FFL" shortens calculated absorption charge time. Lowering "FFL" increases calculated absorption charge time. Adjusted in 2% increments. Span of adjustment is 16% to 96%. To reverse direction of scroll, release magnet and wait for LED to display "FFL" code. Re-activate switch with magnet and release when desired value is indicated.
- **ALI** -- Controls the setpoint at which point field current is reduced when the the alternator temperature sensor indicates an over-temp condition at the alternator. Requires temperature sensor installation. Adjustable from 30°C to 125°C.

Using the Amp Manager

The Max Charge's Amp Manager feature is a unique and powerful tool that's capable of addressing and solving a range of potential issues. By using the Amp Manager to limit alternator horsepower load, you can minimize belt dusting and slippage caused by a too-small belt. Inversely, if your alternator is undersized to support a large battery bank, the Amp Manager function can be used to reduce demand on the alternator and minimize the possibility of alternator overheating.

Notes On Battery Equalization

While the Max Charge regulator is capable of completing an equalization exercise, keep in mind that it may be preferable to conduct an equalization by using a shorepower charger.

Typically, an equalization may require that the batteries be kept at a heightened voltage level for several hours at a time. As a result, it may be inconvenient to be able to run your engine for the required time period. In addition, most battery manufacturers recommend that the batteries be closely monitored (most flooded batteries should be inspected for specific gravity readings periodically, and boiled electrolyte be replaced during the equalization cycle). This may be difficult or impossible if attempting to equalize while underway.

When considering an equalization cycle for your batteries, it is essential to determine the time and voltage requirements of your batteries, prior to initiating the cycle. Your battery manufacturer should be contacted directly for recommendations. Some manufacturers may recommend against equalizations, which may void warranties if attempted against recommendations.

Use added care when equalizing batteries. Intentional overcharging of batteries can result in overheating and release of corrosive gases. Always provide ample ventilation for batteries while equalizing.

VIII. System Troubleshooting

The majority of charging difficulties can be attributed to damage, corrosion or wear at wires or wiring connections. Before attempting to troubleshoot alternator or regulator issues, be sure to address the following:

1. Remove and clean all charging system electrical connections (positive and negative). Check the voltage regulator's harness for resistance. Wires and terminals can and will become corroded, and need to be cleaned or replaced.
2. Charge all batteries to their proper fully charged state, and determine if they are serviceable. If your batteries are flooded-type, use your hydrometer to determine their condition.
3. Check and tighten alternator belt. If the belt shows signs of wear or damage, replace it. Always replace existing belts with the finest quality replacements available.

If batteries and wiring are in suitable condition, use the following tests to determine if charging problems are a result of a faulty alternator or regulator. These tests provide an opportunity to isolate the alternator, regulator and wiring harness in order to determine which component may be malfunctioning. In order to perform these tests, you will need an independent DC meter (preferably a digital type). In an emergency, a 12V light bulb or test light can be used to help determine if power or working grounds exist. An amp meter and a battery hydrometer with a thermometer are also helpful diagnostic tools.

A. Voltage Regulator Test

Set your voltmeter to 12VDC and connect the negative lead to the BLACK ground wire at the regulator as shown at right.

1. With the ignition OFF, check voltage on the red (sensing), blue (field) and brown (ignition) wires in the regulator plug.
2. With the ignition in the ON position (engine not running), check for voltage on the red (sensing), blue (field) and brown (ignition) wires. The voltmeter should read:
3. With the ignition in the ON position (with engine running at 1,400 rpm fast idle), check for voltage on the red (sensing), blue (field) and brown (ignition) wires in the regulator plug.

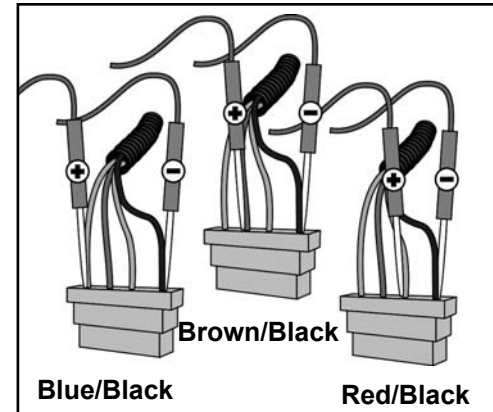

Compare your readings with the table at right. If readings on RED or BROWN wires do not match values shown, check 10-amp and 1-amp fuses, wiring and connections back to their sources. If RED and BROWN match expected readings, but BLUE does not, unplug and re-plug four-prong plug and re-test. If the BLUE wire shows zero voltage and the display is not lit, check connections and fusing on the Positive Battery Sense wire. Check voltage at the base of the Positive Battery Sense terminal with your meter.

If voltage is not present on the RED, the BROWN and the Positive Battery Sense Wire, the regulator will not work. If voltage is as expected at the RED the BROWN and Positive Battery Sense wire, and there is zero, or an unexpected voltage reading at the BLUE wire, contact our technical support staff at (360) 435-6100, or e-mail us at balmar@balmar.net.

If all voltages at the regulator meet expectations, yet the alternator is not producing charging current, we will want to test the alternator. The tests on the following page are recommended for determining alternator functionality.

Expected/Actual	Engine Off	Ignition On	Engine Run
Red Wire	12V*	12V*	12-14V**
Brown Wire	0V*	12V***	12-14V**
Blue Wire	0V*	8-11V**	3-10V**

* 11.5 - 12.8 VDC battery voltage at rest (no charging occurring). If your batteries are isolated and your RED (sensing) wire shows voltages other than those shown above, make sure that the wire is connected on the "battery" side of the isolator. The red wire must "see" the battery directly.

** 13.5 - 14.5 VDC battery voltage when charging.

*** Voltage may be zero with Ignition On/Engine Off if brown wire is connected to an oil pressure switch.

B. Alternator testing

Test A - The alternator and regulator can be tested for function by determining if a magnetic field exists at the alternator's pulley shaft or rear bearing. To test:

1. With the ignition in the OFF position, place the tip of a steel screwdriver near the nut on the pulley shaft or near the rear bearing of the alternator. There should be no evidence of a magnetic field pulling the screwdriver toward the alternator. (A slight amount of magnetism may be present, due to residual voltage in the alternator.)
2. Engage the ignition, without starting the engine, to activate the voltage regulator. If an oil pressure switch is used, a jumper between the RED and BROWN wires in the Ford-style plug will activate the regulator.
3. After allowing time for the regulator's start-up delay, place the head of a steel screwdriver near the nut on the pulley shaft or near the rear bearing of the alternator. There should be substantial magnetic pull. If a magnetic field is present, the voltage regulator, alternator brushes and rotor are likely to be working properly.

Test B - If there is little or no magnetic pull at the pulley shaft or at the rear bearing, initiate the following test:

1. With the key off and the engine off, remove the large harness plug from the regulator.
2. Insert the end of a short length of electrical wire to the RED connector slot of the regulator harness and the other end of the wire to the BLUE connector slot. (See Figure 24.) This bypasses the regulator and tests the alternator and the harness.
3. Using your steel screwdriver, inspect for a magnetic field as described above.
4. With your voltmeter, check for voltage on the blue wire at the alternator. If voltage does not exist, the harness may be at fault. If voltage does exist at the harness, but no magnetism is present, the alternator is likely to be malfunctioning.

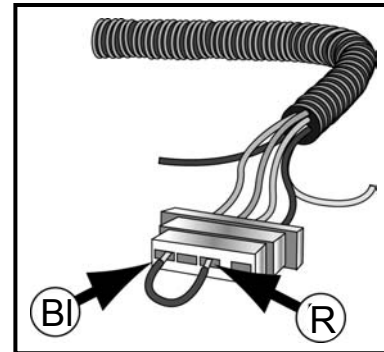

Figure 24 - Jumping power wire to field.

If a magnetic field is present. Both harness and alternator brushes and rotor appear to be working properly. If no magnetic field is present, proceed with the next test.

Test C - Testing the actual output of the alternator is known as “Full Field Testing”. This can be accomplished by jumping a positive 12VDC current to the field terminal at the rear of the alternator. This test eliminates both the regulator and the harness, making it easier to isolate your investigation to the alternator. **CAUTION:** Ensure that all voltage sensitive equipment is turned off prior to starting the engine. Voltage is unregulated during this test and could damage sensitive electronics. **DO NOT** let the engine run any longer than necessary to detect charging. If the system is not charging, remove the alternator and have it inspected by a qualified alternator shop, or call Balmar for warranty evaluation.

To test the alternator:

1. Clip a jumper wire to the positive post of the alternator, or on the battery side of the isolator (if an isolator is in use). Use a SHIELDED alligator clip for post attachment. Unintentional contact between the alligator clip and the alternator case could result in damage to your electrical system.
2. Disconnect the field/stator plug from the rear of the alternator and attach the other end of the jumper wire to the alternator's Field terminal (F). Attach a female spade connector to the field end of the wire for a solid connection. **CAUTION:** Do not allow the wire to contact the case while it is attached to the positive post. The case is grounded and severe damage could occur.
3. The regulator is now bypassed. When the ignition is engaged and the motor is started, the voltage should rise and charging current should be present.
4. The motor should be run long enough to determine that charging voltage is present. Unregulated voltage can rise quickly. Do not allow extended unregulated charging to occur without carefully monitoring voltage levels.

If the alternator fails to generate voltage during field testing, a malfunction of the alternator is likely. Contact your local alternator repair shop or Balmar's technical service staff for recommendations.

C. Conclusion

If your readings differ substantially from the “Expected Readings” listed in the troubleshooting charts, the regulator may be malfunctioning, or there may be a continuity problem. Contact our technical support staff at (360) 435-6100. If you determine that repair service is necessary for either your alternator or regulator, please gather the following information before contacting our service technicians: Make and model of alternator. Model of voltage regulator and date of mfg. (date punched on rear side label of regulator). Voltage readings on red, brown and blue wire at regulator with engine off, key on. Voltage readings on red, brown and blue wire at regulator with engine running at a fast ideal 1400 rpm.

II. Suggested Wiring Configurations

The following provide some suggested direction in regard to charging system configuration.

**Dual-Output Alternator
Start/Two House Battery Banks - With Duo Charge**

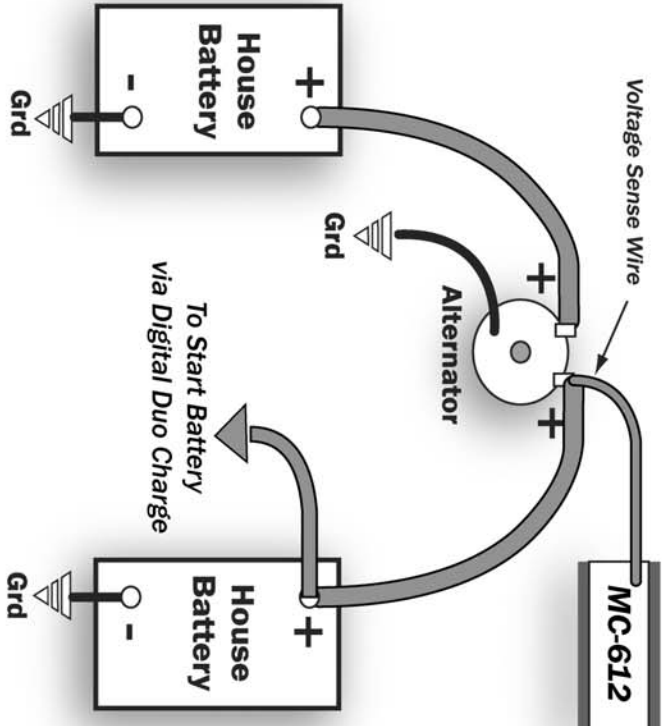

**Single Output Alternator
Start/Two House Battery Banks - With Duo Charge**

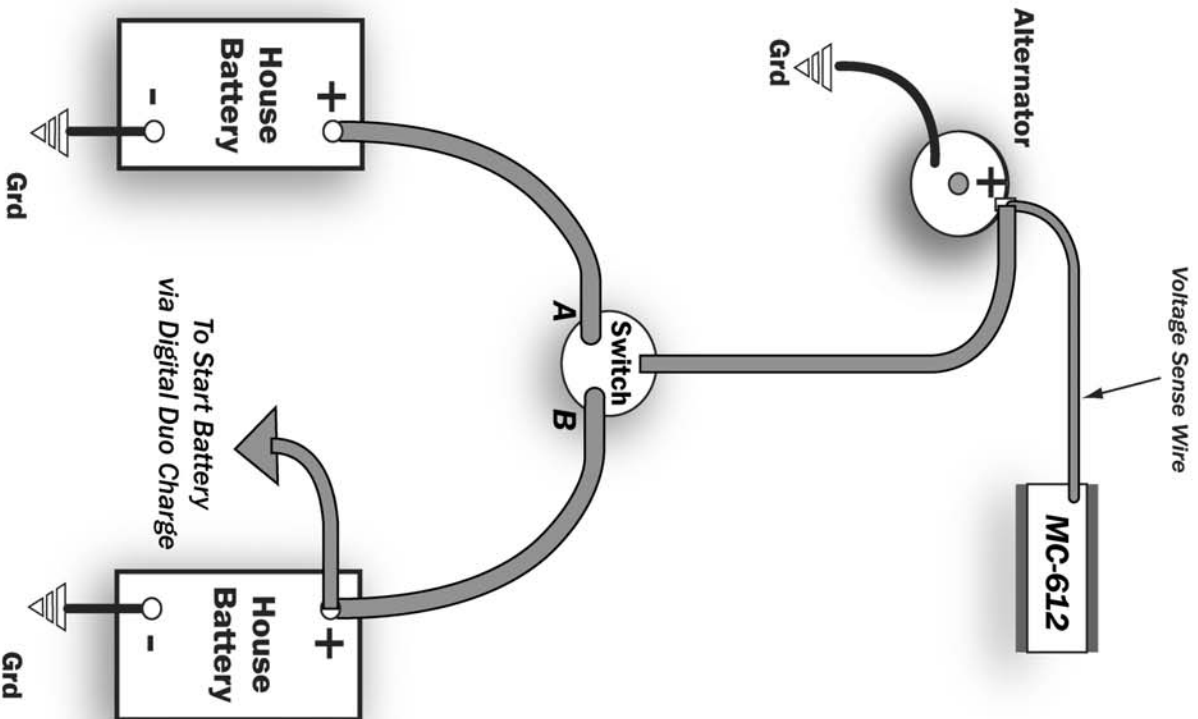

**Single Output Alternator w/Isolator
Start/Two House Battery Banks - With Duo Charge**

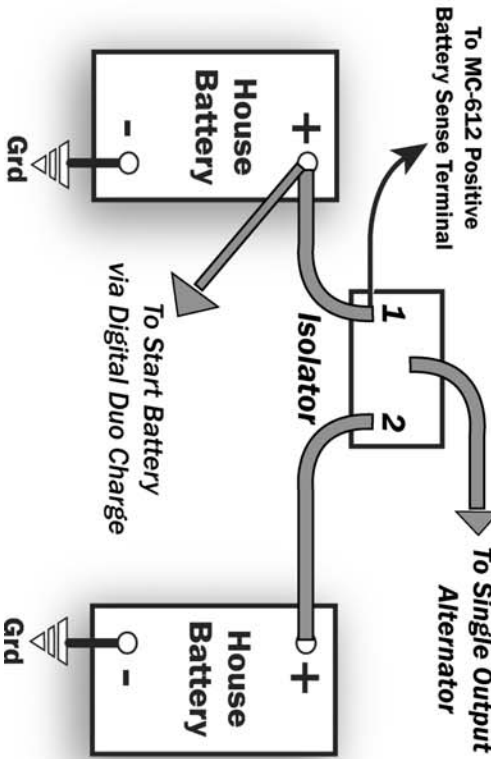

**Single Alternator / Single Regulator
Start/House Battery Banks - With Duo Charge**

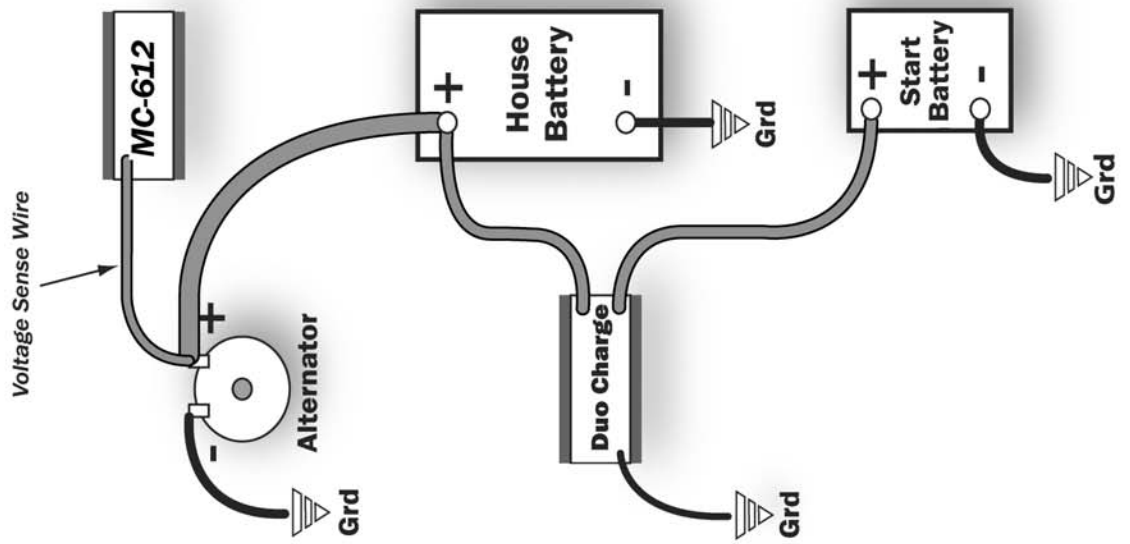

**Twin Engines / Dual Alternators / Dual Regulators
House / Start Battery Banks - With Centerfielder & Duo Charge**

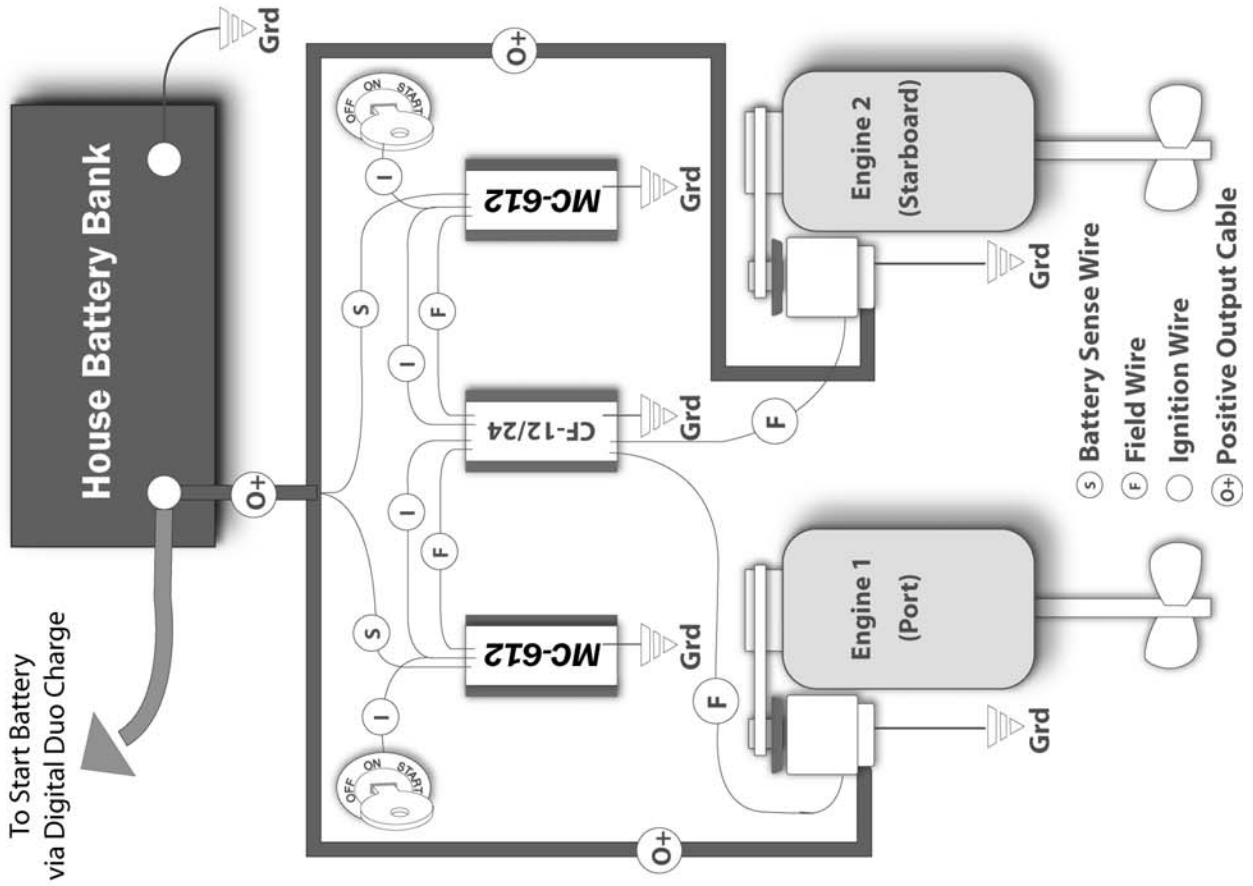

Express Installation Instructions

1. Mount regulator on a secure surface in a location with adequate airflow.
2. Disconnect battery leads, or switch main power supply to OFF position.
3. Verify that wiring harness is securely connected to regulator.
4. Connect two BLACK ground wires to alternator ground terminal. Ground wires must see common system ground.
5. Connect RED regulator power wire to positive output of alternator or other constant source of battery voltage.
6. Connect BLUE regulator field wire to alternator's field connector. Consult alternator manual to ensure proper location of wire terminal.
7. Connect BROWN ignition wire to a switched source of battery voltage. This may be at the ON side of the ignition switch, or at an oil pressure switch.
8. Connect positive voltage sense wire to positive output of alternator or other constant source of battery voltage. This wire must be fused at one amp. Use included fused wiring pigtail at the source end of the wire run. User-supplied wire is required for the remaining run to the regulator's. Plug regulator end of wire into the positive voltage sense terminal on regulator.
9. If an electrical tachometer requires a stator pulse for operation, connect the WHITE stator wire to the stator/AC tap terminal at the alternator. Connect the other end of the WHITE stator wire to the "Stator In" terminal on the regulator. Connect your tach wire to the "Tach Out" terminal on the regulator.
10. Re-connect batteries to system, or turn main battery switch to ON position.
11. Turn engine ignition on. If oil pressure switch is supplying power to BROWN ignition wire, start engine.
12. Regulator LED should be activated and should scroll through the regulator's short display.
13. Regulator is pre-set for factory UFP setting. This should be safe for most battery types. If greater charging efficiency is desired, follow Basic Programming instructions in Section VII of this manual.

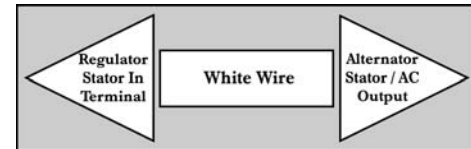
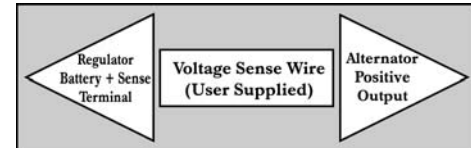
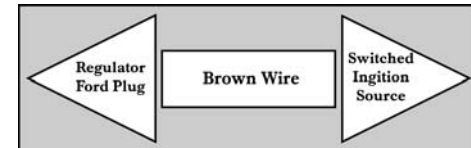
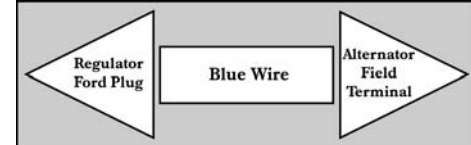
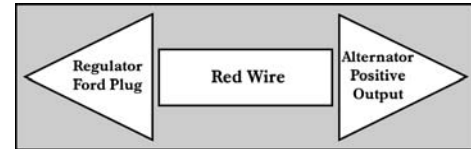
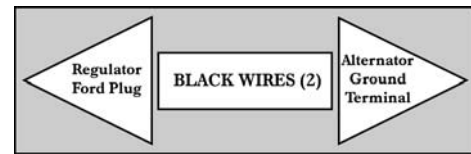

LIMITED PRODUCT WARRANTY

BALMAR warrants to the original consumer/purchaser the product is free from any defects in material or workmanship for a period of one year from the date of purchase. If any such defect is discovered within the warranty period, BALMAR will replace the regulator free of charge, subject to verification of the defect or malfunction upon delivery or shipping prepaid to BALMAR.

This warranty DOES NOT apply to defects or physical damage resulting from abuse, neglect, accident, improper repair, alteration, modification, or unreasonable use of the products resulting in breakdown, cracked or broken cases nor are parts damaged by fire, water, freezing, collision, theft, explosion, rust, corrosion or items damaged in shipment in route to BALMAR for repair. BALMAR assumes no responsibility for consequential damage or loss or expense arising from these products or any labor required for service or repair.

BALMAR WILL NOT repair or be held responsible for any product sent without proper identification and return address or RA number clearly marked on the package. You must include proof of date and place of purchase (photocopy of purchase invoice) or we cannot be responsible for repairs or replacement. In order to expedite warranty claims more efficiently, BALMAR asks that prior to returning a defective product for repair, you call their customer service department for a warranty return authorization number.

If factory service is required, you can contact our BALMAR Customer Service Department Monday through Thursday, 7:30 AM to 5:30 PM, (PST)1-360 435-6100 ext "3".

Material required for the repair or replacement for the defective part or product is to be supplied free of charge upon delivery of the defective regulator to BALMAR, 19009 61st Ave. NE, Arlington, WA 98223. Customer is responsible for all return transportation charges and any air or rush delivery expense. BALMAR reserves the right to determine whether to repair or replace defective components.

THE ABOVE LIMITATIONS MAY NOT APPLY TO YOU. SOME STATES DO NOT ALLOW LIMITATIONS ON HOW LONG AN IMPLIED WARRANTY LASTS. NO PERSON, AGENT, DEALER IS AUTHORIZED TO GIVE ANY WARRANTY.

BALMAR 19009 61st Ave. NE, Arlington, WA 98223 Phone: (360) 435-6100, Fax: (360) 435-3210
E-mail: balmar@balmar.net, Web: www.balmar.net